

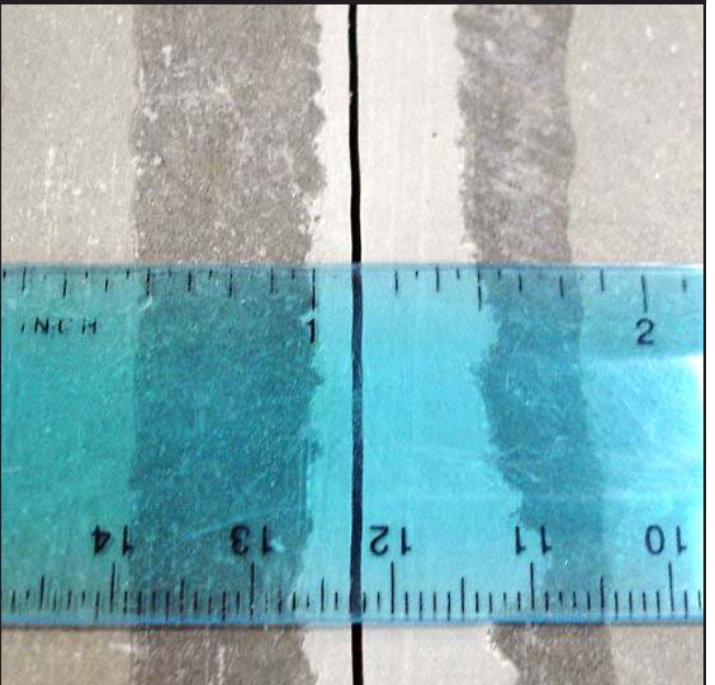

***FOCUS ON***

***INDUSTRIAL  
FLOOR JOINTS***



---

***FOCUS ON***

---

# ***INDUSTRIAL FLOOR JOINTS***

Copyright 2005 Metzger/McGuire, Inc. All Rights Reserved

by **Steve Metzger**  
**Metzger/McGuire**

---

## **OUTLINE OF CONTENT**

---



- I. THE IMPORTANCE OF INDUSTRIAL FLOOR JOINTS**
- II. FLOOR DESIGN DETERMINES JOINT DESIGN**
- III. JOINT DESIGN PRINCIPLES**
- IV. BASIC JOINT TYPES AND DESIGN**
- V. SLAB SHRINKAGE**
- VI. PROVIDING FOR SLAB SHRINKAGE**
- VII. JOINT FILLING**
- VIII. POST-FILLING**
- IX. THE FIRST YEAR**
- X. SUMMARY**

*Additional copies of this article are available at no charge upon request.*



**800-223-MM80**

**[www.metzgermcguire.com](http://www.metzgermcguire.com)**

P.O. BOX 2217 CONCORD, NEW HAMPSHIRE 03302

FAX: 603.224.6020

E-MAIL: [mminfo@metzgermcguire.com](mailto:mminfo@metzgermcguire.com)

# FORWARD

In a recent survey of facility professionals we asked the participants to identify their most “significant” concrete floor problem.

***An astounding 92% responded with the answer "deteriorated joints."***

Joint deterioration has been a problem ever since the first hand-pushed cart was rolled across a concrete floor. It became a noticeable problem when pallet jacks and similar equipment was introduced. Now, with today's large and sophisticated material handling vehicles so common, joint deterioration is reaching crisis proportions, especially in the warehousing and distribution industries. To a large degree the material handling industry sets the criteria that we in the concrete floor industry must meet.

Here are some actual comments we received back from our survey...

*"My wheel replacement costs are double our company average. HQ is on my back even though I tell them I've got the worst floor of all our DC's."*

*"My vehicles are designed for high speed use, but I can't use them at high speeds because my joints are so badly deteriorated."*

*"I couldn't get any budget money for floor repairs until a load tipped and the driver got hurt. Now I get \$4,600 each year for floor repairs. It's not nearly enough, but it's more than I had."*

*"I've been pushing for a transfer to our newer DC. I'm tired of having my chances for a promotion limited because our floor is in such lousy shape, and HQ blames our low productivity on my lack of ability."*

The goal of this article is to help you avoid joint deterioration problems in the future by gaining a better understanding of joints in industrial floors on ground and the critical design and construction issues involved in providing a floor joint system that will prove as durable as the floor itself.

## I. THE IMPORTANCE OF INDUSTRIAL FLOOR JOINTS

The primary function of an industrial concrete floor is to act as a work surface for the manufacture, storage and/or movement of raw materials or finished goods. It goes without saying that the best work surface is one that provides a smooth, hard and interruption-free platform for the facility operations. Unfortunately, concrete floors must have joints, and joints are interruptions in an otherwise continuous surface. Each joint is a potential impact point for hard wheeled traffic.





## ***I. THE IMPORTANCE OF INDUSTRIAL FLOOR JOINTS***

When a material handling vehicle runs across an interruption-free floor, it can operate at its designed optimum speed and thus achieve its intended productivity rate. But when a floor has deteriorated joints, several negative effects occur;

- 1. Vehicle operators slow down as they approach the joints to avoid jolts.*
- 2. The vehicle wheels get chewed up and must be replaced, resulting in vehicle downtime, maintenance, personnel time and expense, and wheel replacement costs.*
- 3. When defects are severe, the results can be lower back distress claims by drivers, the danger of load tipping, etc.*
- 4. As traffic continues to cross the joints, the defects grow wider and deeper, and eventually will require expensive, time consuming repairs.*



***Deteriorated joints create an interruption in the continuity of the floor surface, leading to operational slow-downs and increased vehicle maintenance costs.***



When we in the concrete industry design or construct an industrial floor, we must always be cognizant that joints are part of the floor surface, and that every joint poses a potential long term problem for the facility owner or tenant. We must therefore make sure that every joint will stand up to the operations planned for the facility.

## ***II. FLOOR DESIGN DETERMINES JOINT DESIGN***

There is no such thing as a “standard floor design.” Every floor, and the joints in that floor, must suit the intended facility use.

Typical floor design consideration include;

### ***1. Facility Function***

Distribution centers with constant traffic flow have different needs than a manufacturing plant with less frequent traffic but using steel wheeled carts. The floors in so-called discount retail stores (Home Depot, Sam's Club, etc.) have an aesthetic as well as a functional factor to consider since they are also showrooms.



***There is no “standard floor design” because each industrial floor has a variety of demands placed upon it depending on material handling vehicle types, load weights, frequency of traffic, etc.***

## **II. FLOOR DESIGN DETERMINES JOINT DESIGN**

### **2. Environment**

Facilities may be temperature controlled (heat, AC, fans) or reflect outside temperatures, be refrigerated (coolers, freezers), etc. In each case joints will act differently and require different design considerations.

### **3. Vehicles**

Facility vehicles may have 12" (30 cm) diameter cushioned tires or 4" (10 cm) diameter solid wheels with a thin coating. Facilities might use hand-pushed pallet jacks, traditional forklifts or high-bay stacker-pickers. Vehicle + load weights can go to tens of thousands of pounds. Additionally, some vehicles may require floor flatness criteria that exceeds which can be achieved using conventional floor placement and finishing methods.

### **4. Operations**

Some facilities operate one shift/day and 5 days/week while others run 24/7. Facilities with more intense schedules not only place greater demands on floor and joint durability, but also have almost no time available for the repair or maintenance of joints.

### **5. Owner Expectations**

Some owners want a first class floor that will last for years, while others may have a shorter time horizon in mind. Some will pay for a premium floor, while others insist on a bare-bones floor with a budget to match. Some owners may want the number of joints held to a minimum, yet others have no objections to more joints as long as they don't deteriorate.

### **6. Site Conditions**

The condition of the land the floor is placed on can have major design implications. Sites with swampy conditions or expansive soils may need a different design than floors on more stable grades.

### **7. Mix Design**

Concrete mix design can vary due to many factors including local practices, local aggregate availability, etc. Joint spacing and design must take these factors into account.

When all these factors are considered it is possible one or more of the following floor design criteria may be most appropriate;

- a. Conventional floor; reinforced or non-reinforced**
- b. Shrinkage compensating concrete**
- c. Flat, superflat**
- d. Post-tensioned**

Once the floor type has been selected, the jointing system must be tailored to match both the floor design and facility function.



**High rack lifts place higher demands on floor joints due to their smaller, harder wheels and increased point loads.**

### **III. JOINT DESIGN PRINCIPLES**

Although we talk about floors as if they were one entity, they are not. When speaking about floors it is critical that we recognize that each floor is composed of numerous smaller floor segments, both connected and separated by joints.

A 100,000 sq. ft. (9,290 sq. meters) building with 15'x15' (5mx5m) joint spacing will have approximately 400 panel segments. Proper joint design must provide the means for all these floor segments to function in unison as though they were one floor as traffic flows across the floor, while also allowing each slab to expand or contract independently when necessary.

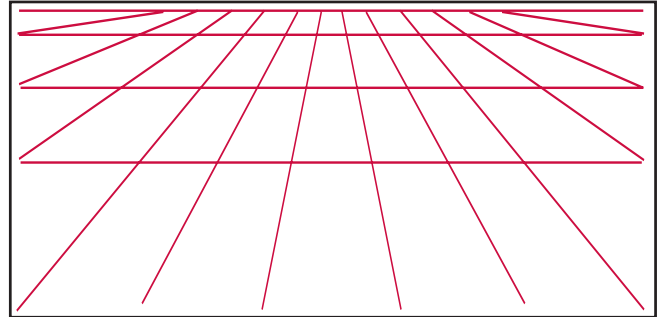

***A typical industrial floor is not “one” slab, but rather a series of slabs both connected and separated by joints.***

The guiding objectives in joint design must always be to provide joints that will recreate the pre-jointing continuity of the floor surface, and do so in a manner that will make the joints as durable as the floor itself. To achieve these goals joints must have the following characteristics;

#### ***1. Joints should be “narrow”***

Joints should always be as narrow as possible to minimize their overall exposure to hard wheels. A 1/4" (6.5mm) wide joint has twice the exposure to wheel impact as a 1/8" (3 mm) joint. This width difference can be critical when joints are subjected to 4" diameter, solid wheel traffic. Early entry saws have allowed for standard joint widths to be narrower than was possible with wet cut saws.

#### ***2. Joints must be “plumb” (vertical)***

Joints that are not perpendicular to the floor surface plane will have an overhang on one side. This overhang can readily be broken off by traffic loads.

#### ***3. Joints must have “load-transfer”***

For all the smaller floor segments to act in unison under load they must be “connected,” so individual panels do not deflect under load. This load transfer is generally accomplished with the use of dowels or through “aggregate interlock,” though aggregate interlock is not normally sufficient as slabs contract and joints open wider than originally sawn.

#### ***4. Joints must be “protectable”***

Joints must be created in a way that allows a subsequent joint filler to protect joint edges from wheel inflicted damage. For a filler to properly protect a joint, the joint needs to have 90° vertical walls (i.e. not “tooled”) and certain minimum width and depth dimensions may be necessary.



## IV. BASIC JOINT TYPES AND DESIGN

There are four basic joint types one might find in industrial concrete floors;

1. **Construction Joints**
2. **Contraction Joints**
3. **Isolation Joints**
4. **Expansion Joints**

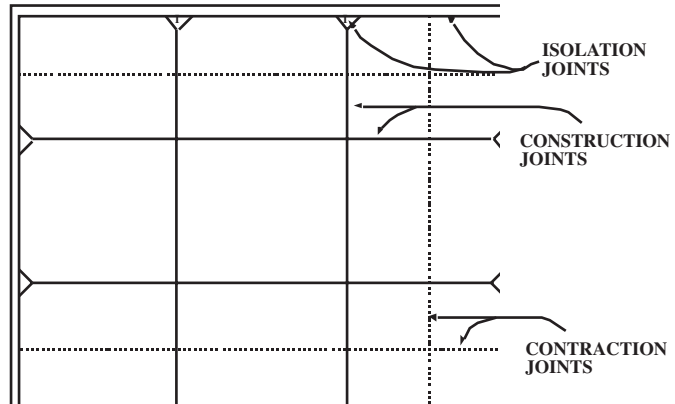

### 1. Construction Joints

Floors are placed in sections called “pours.” The junction where a new pour meets a previously placed pour is called a construction joint, or a formed joint. Construction joints for most industrial slabs are generally “butt” joints that extend straight down the full slab depth. “Keyed” joints are seldom used anymore because they add to forming costs while yielding no substantial benefit. Left-in-place metal screed keys should never be used. Experience has shown that the cantilevered lip often breaks off under heavy traffic, creating extensive damage.



Future ACI documents will recommend that construction joints be saw cut 1" (25 mm) after the concrete has hardened and a crack develops. This saw cut creates a reservoir for a joint filler, reveals any inherent weakness in the formed joint edge due to lack of densification, and makes all joints look the same. The use of a 1/8" (3 mm) radius edging tool on the first pour creates a guideline for the saw to follow.

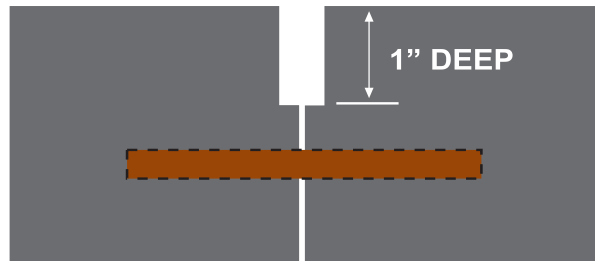

**Construction joints should be saw cut to 1" deep.**

In some cases construction joints are “armored.” Armoring is achieved by the use of a steel bar, a steel angle, or a structural epoxy resin. Armored joints are recommended when vehicles are extremely heavy, or when the joints are expected to widen substantially. Typical applications of armored joints include joints in shrinkage compensation concrete, at the ends of long strip pours (i.e. post-tensioned slabs), at joints between adjacent rooms, etc.

## **IV. BASIC JOINT TYPES AND DESIGN** *(continued)*

### **2. Contraction Joints**

Also known as “control joints,” contraction joints are created by saw cutting at intervals between the construction joints. The function of contraction joints is to reduce the potential for random cracking within the slab panels caused by the linear shrinkage of the panel as slab moisture evaporates. The sawn joint creates a weakened plane in the concrete, inducing the expected shrinkage crack to develop below the cut. In effect, a contraction joint is a guided crack that remains unseen.

There are two basic methods of saw cutting contraction joints—the conventional “wet cut,” and the “early entry” dry cut. The wet cut saw can be used only after the slab has hardened sufficiently to support the saw's weight, perhaps 6-16 hrs. The early entry saw is generally used within a few hours after finishing. Wet cutting must provide a cut one-quarter of the slab depth. Early entry cuts require less depth because they induce the plane of weakness before shrinkage stresses are significant. Joints in steel fiber reinforced floors are usually cut to one-third of slab depth.

The benefits of the early-entry saw systems are that they reduce the potential for random slab cracking, and that they leave more concrete beneath the cut, thereby increasing the chances of obtaining effective aggregate interlock. The possible negatives with early-entry saws are that they can cause micro-fracturing of the edge if the blade is dull, wobbles or if it dislodges aggregate instead of cutting through it. These problems are due more often to contractor error and neglect than with the saws themselves. Some in the industry use the early-entry saw initially, then re-saw later with a conventional saw. The saw laitance left on the adjacent surface should be removed before it hardens.

### **3. Isolation Joints**

Isolation joints are placed where the slab meets a vertical surface such as a wall. Their function is to separate building components. Isolation joints are also used to separate slabs from column pads.

### **4. Expansion Joints**

Expansion joints (EJ's) are rarely found in floors anymore.

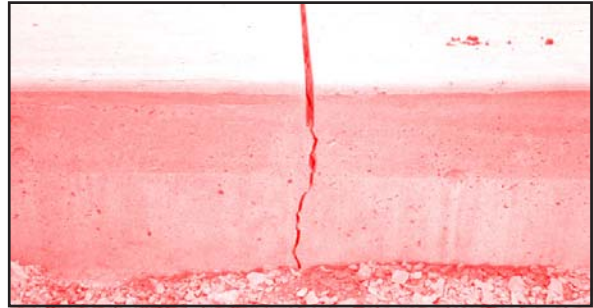

**Saw cut contraction (control) joints are designed to control where cracking occurs in the slab.**



**Traditional “wet cut” saws require sufficient slab cure to support the saw's weight.**



**“Early Entry” saws allow for joint cutting to be performed within hours of slab placement, reducing the potential of random cracking and allowing for a shallower joint depth to induce cracking below the joint.**



## V. SLAB SHRINKAGE

At the heart of all floor design and joint design is the fact that all concrete shrinks. A concrete slab is never larger than it is on the day it is placed. From day one forward, the linear dimension of each slab panel gets shorter as the excess water in the concrete evaporates. Shrinkage results in joints becoming wider, which means greater exposure to hard wheel traffic. It can also result in the loss of connectivity (load-transfer) between slab panels, allowing each panel to function independently rather than in unison with adjacent panels.

When designing a floor, a good rule of thumb is to assume that a 20' long (6 m) panel will shrink about 1/8" (3 mm). This means that with 20' joint spacing, each joint that is initially 1/8" (3 mm) wide will eventually open to 1/4" (6 mm).

A second rule of thumb to remember is the rate of shrinkage. It is generally accepted that 30% of the expected shrinkage takes place in the first 30 days after the pour. Another 50-60% takes place over the next 11 months, bringing the one year total to 80-90% of expected shrinkage. The balance takes years or decades. Since most industrial projects take less than a year to build, it can be assumed that the floor will still be shrinking after the owner takes occupancy. This slow shrinkage rate is the cause of many owner-contractor misunderstandings and conflicts.

**Portland Cement Association (PCA) Shrinkage Chart**

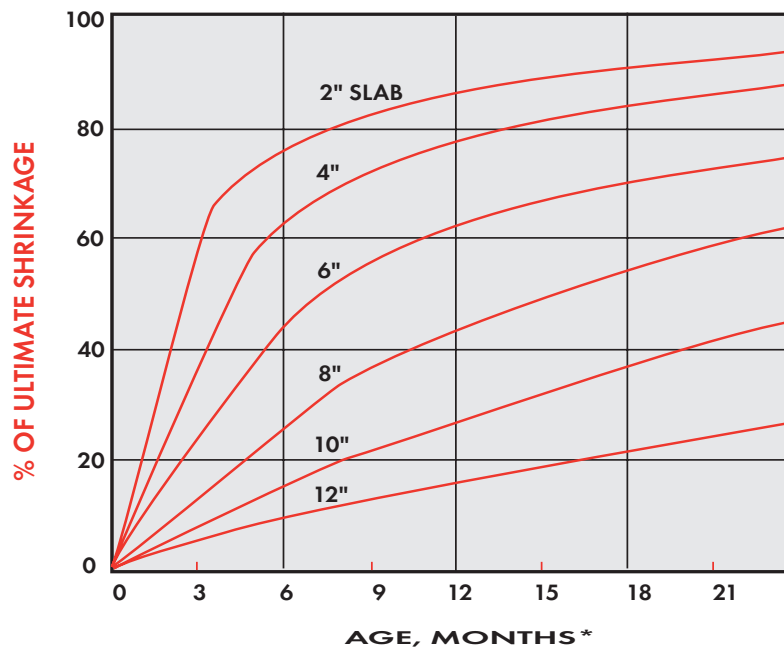

\* Drying in Laboratory Air from PCA Dev. Dept. Bulletin 103

If you were to survey a conventionally poured floor with 20' (6 m) joint spacing 7 days after placement, you would likely find that the joints are still at their original width. If you ran a forklift over the slab you would find that all slab panels are working together as one slab due to concrete-to-concrete friction at construction joints, and aggregate interlock beneath the saw cut contraction joints. But if you run that same forklift after a 30-60 day slab cure, you would find the joints to be 1/16" to 1/8" (1-3 mm) wider. You might also find each panel acting alone. This is because slab shrinkage has caused a loss of connectivity between the panels, and the floor will prove to be unsatisfactory for most industrial operations.

## V. SLAB SHRINKAGE (continued)

Another adverse result of slab shrinkage is “slab edge curl.” Slabs dry from the top down because slab moisture is lost via evaporation into the air. While the top of the slab is drying and shrinking at a significant rate, the bottom is hardly shrinking. This uneven drying can cause the top of the slab to “curl” up at panel ends, much like what you will see in a dried up river bed.

Curl can cause the slab ends to lift up off the grade, leaving it cantilevered. When traffic loads are imposed upon a curled slab end, the slab can deflect, causing the panel to “rock” as traffic passes.

Heavy loads can cause the slab end to crack, even break-off. When a panel deflects, the joint edge of the adjacent panel remains high, exposing it to impact by vehicle wheels. The result is severe edge spalling.

When we design a floor, and floor joints, we must always look beyond the early stages and design for what the slab will look like 3 months, 6 months and 12 months afterward.



**Slab edge curl can occur when the top of the slab dries at a significantly faster rate than the slab bottom. A curled edge creates an impact point at the joint, and left untreated will likely spall under material handling vehicle traffic (below).**

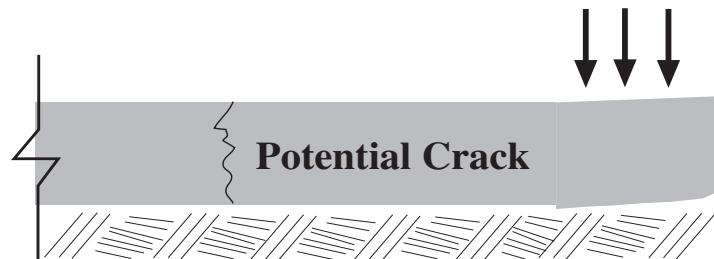

**Severe slab edge curl can cause the panel edge to actually lift off the grade, creating a void beneath the panel edge. Heavy loads crossing the cantilevered panel edge may cause the panel to crack or completely break off.**

## VI. PROVIDING FOR SLAB SHRINKAGE

The effects of slab shrinkage and slab edge curl are directly related to slab thickness and the designed joint grid spacing and layout. Most grid layouts are related to column spacing. For example, a conventional 6" thick slab with 40' (12 m) column spacing may have the interim contraction joints cut at either mid-point or one-third points. Mid-point spacing of 20' (6 m) will likely see joints eventually open 100%, 1/8" to 1/4" (3 mm to 6 mm). One-third point spacing (13'-4"/4 m) will see joints open proportionately less. Either amount of opening will cause a lack of connectivity between panels and between pours. A major problem is that we can't predict whether the shrinkage-related opening will manifest itself at construction joints only, contraction joints only, or both. We also can't be certain that all joints that open will open equally. The designer must bear these variables in mind when designing the floor.

With non-doweled construction joints, load-transfer is lost as soon as joints open. With contraction joints, it is generally accepted that load-transfer from aggregate interlock starts to be compromised when the crack beneath the joint exceeds 0.035 in. (0.9 mm). The only sure way to achieve load-transfer at construction joints is through the use of dowel devices. For contraction joints, effective load-transfer may require dowels, or reinforcement extended through joints. A reduction in joint spacing to reduce the amount each joint opens may suffice, but cannot always be relied upon.

It can safely be said that all joint edges suffer curl. It's only when curl is significant enough to interfere with material handling vehicle operations that it poses a problem. The degree of curl can be minimized in the mix design (less water, less cement, larger aggregate, etc.). The effects of curl can be minimized by with tighter joint spacing. Shorter panel spacing reduces the shrinkage stresses across the top of the slab. Dowels can also help minimize the adverse effects of curl by providing load-transfer from panel to panel, thus reducing how much the panels can move vertically.

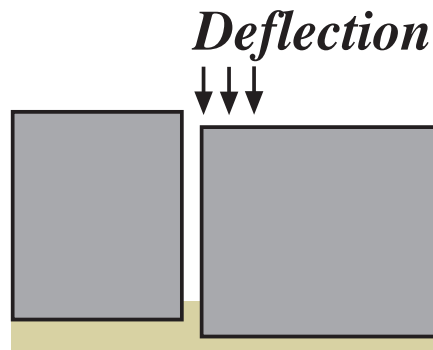

*After shrinkage occurs, non-doweled construction joints provide no load transfer from one slab panel to the next, which may result in slab panels deflecting, leaving uneven elevations at the joint.*

*Adequate load transfer may be achieved at contraction joints if joint spacing is reduced to keep the shrinkage crack below the saw cut at 0.035" (0.9 mm) or less in width, but the effectiveness can vary.*



*In theory, all joint edges likely suffer from some degree of curl. Whether the curl is significant or not is determined by whether it interferes with the material handling operations and leads to joint edge deterioration.*



# VI. PROVIDING FOR SLAB SHRINKAGE (continued)

The three most common types of dowel systems are the round (smooth) dowels, the square (smooth) dowels, and the “plate” dowel. One of these systems should always be used at construction joints when heavy loads and/or frequent traffic is expected. With all three types, one side must be allowed to slide smoothly to allow for joint movement. This can be achieved by greasing one half of the dowel, or providing a sleeve that isolates the dowel from the concrete.

The size and spacing of dowels should be determined by the designer, based on expected loads, etc. It is critical that dowels be set at the proper depth, and at a 90 degree angle from the joint. Dowels placed too low will not provide adequate load-transfer. Dowels placed too high, or at other than a 90 degree angle, will result in slab damage as the slab moves laterally or vertically. The best location for dowels is at mid-depth of the slab.

The “plate” dowel offers load-transfer capabilities comparable to the round and square dowels, while eliminating their potential for horizontal restraint. Such restraint can occur when one panel is shrinking at a different rate than the adjacent panel due to an age difference.

Contraction joints may also require load-transfer devices, especially when loads are very heavy or joints are widely spaced.



When round or square dowels are used at contraction joints, placement directly under the subsequent joint is critical.

In some cases a designer may use “tie bars” instead of smooth dowels. Tie bars are “deformed” steel bars that ensure contraction joints will open little, if at all. The negative side of using tie bars is that all of the accumulated shrinkage can take place at construction joints, or panels can suffer random cracking.



Round (Smooth) Dowels

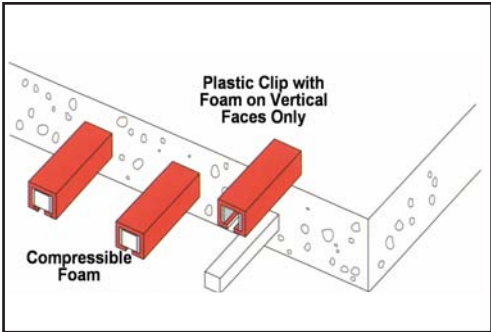

Square (Smooth) Dowels



Plate Dowel



*It's critical that dowels be set at the proper depth and at a 90° angle from the joint to avoid slab damage.*

## VI. PROVIDING FOR SLAB SHRINKAGE (continued)

Some designers or owners may prefer to have the fewest amount of joints possible. Their objectives may be to reduce future joint maintenance, avoid objectionable curl or achieve higher flatness readings required for some sophisticated material handling vehicles.

The most common means of reducing joints include heavy reinforcing, steel fiber reinforcing, using shrinkage-compensating concrete and post-tensioning. With each of these the trade-off often is greater opening at construction joints. Such joints should be “armored” with steel angles or steel bars. The bar is preferable because greater densification of the concrete at the joint is possible.

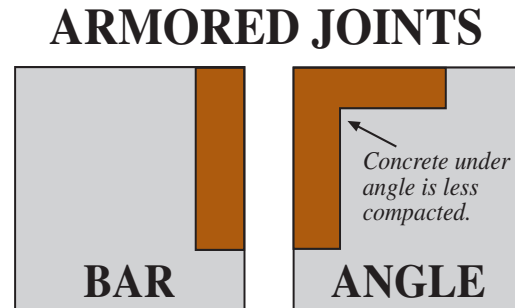

Armoring joint edges with a structural epoxy nosing is another option, although these joints are more expensive to create. They may also prove less durable since they are totally reliant upon the epoxy-to-concrete bond.

Joints in freezer and cooler room floors bear special attention. All joints open due to normal concrete shrinkage, but joints in freezers and coolers open even wider due to thermal shrinkage of the slab. It is not uncommon in a freezer to see 1/8" (3mm) wide saw cuts open to 3/8" (10mm) or more. This additional width is a significant problem when vehicles have small diameter wheels.

Joint spacing and layout are a critical element in minimizing the adverse effects created by shrinkage. Panels should always be kept as square as possible. Rectangular panels tend to develop random cracks about halfway in their long dimension due to unequal shrinkage stresses. Additionally, joints at the ends of the panel's long dimension will open wider than those at the end of the panel's shorter dimension.

Construction joints tend to have weaker edges than contraction joints due to less concrete densification. This condition can be minimized by running the trowel up to the formed edge instead of troweling by hand. The best practice is to create a jointing layout where the construction joints are exposed to minimal traffic. For example, provide a joint layout where construction joints are located within the racking system.

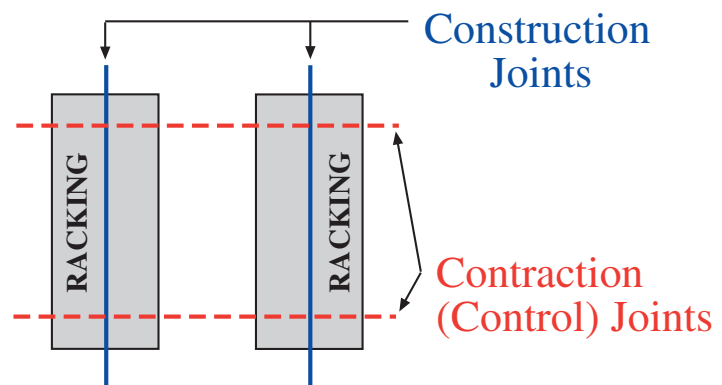

**Careful attention should be paid to the layout of the joints within a facility floor plan. Construction joints are the most vulnerable to deterioration and should be placed within racking as often as possible to minimize exposure to traffic.**

Proper curing adds strength to the joint edges. When wet curing a good practice is to temporarily fill joints with wet sand.

## **VI. PROVIDING FOR SLAB SHRINKAGE (continued)**

**Here are some of the most common causes of joint problems for owners, not necessarily in order of frequency or severity;**

- 1. Saw cuts made too early or too late**
- 2. Early-entry cuts made with worn “skid plates” or blades**
- 3. Joints spaced too widely**
- 4. Lack of dowels (no load-transfer)**
- 5. Dowels improperly positioned**
- 6. Excessive curl due to joint spacing, poor mix design, etc.**
- 7. Rocking slabs due to curl and/or lack of load-transfer**
- 8. Inadequate densification at construction joint edges**
- 9. Lack of adequate curing at joint edges**
- 10. Failure to armor joints where appropriate**
- 11. Joints that open too wide (numerous causes)**
- 12. Reliance on aggregate interlock for load-transfer**
- 13. Not minimizing number of joints exposed to traffic**
- 14. Failure to fill joints**
- 15. Improper filling of joints (wrong material, inadequate filler depth, inadequate cleaning of joint before filling, concave filler profile, etc.).**



***Improper filling of joints (in this case inadequate filler depth) is just one of many common causes of joint problems an owner may face, but it is one of the most easily preventable.***

One of our industry's problems is our failure to educate facility owners about floors and floor joints. We should be telling owners in advance that their floor is still shrinking even as he moves in, and that his joints are still widening. We need to tell him that his joints will be narrower in the summer, and wider in the winter due to thermal expansion and contraction. This means he may have slabs that “rock” in the winter but not the summer. And we need to tell him that joint edges will “spall” (deteriorate) unless they are properly filled and maintained.



## VII. JOINT FILLING

As previously stated, the best floor is one that offers a continuous surface upon which operations can run at optimum efficiency. Joint filling is the key to achieving that goal. The primary function of joint filling is to restore the surface continuity we destroyed by creating joints. Joint filling also protects joint edges from damage caused by hard wheel impact and heavy load pressure.

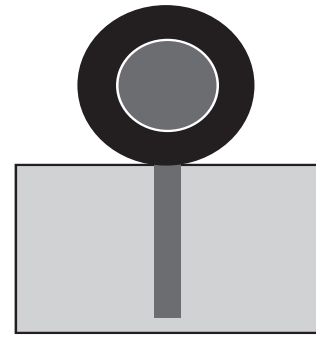

Note we use the term joint “filling,” not joint “sealing.” The terms “sealing” and “sealant” imply we are trying to prevent something from going into the joint, like moisture or air. With floor joints subject to hard wheel traffic we are “filling” the joint, replacing the concrete that was removed. For this reason floor joint filling should always be specified in the Concrete (03300) Section. A cross-reference in the Caulking & Sealant (07900) Section is wise since most joint filling is performed by sealant contractors. There are no federal or ASTM specifications for floor joint fillers as there are for sealants. The only acceptable use of sealants in an industrial floor is in joints not subject to traffic (isolation joints at walls, column pads, under racks, etc.).

Joint filling is a “system” consisting of the proper filler, installed at the optimum time, using the proper installation techniques.

There is no “ideal” joint filler. An ideal filler would be one that is soft enough to expand as the joint opens due to shrinkage, yet hard enough to support hard wheeled traffic without deflecting. Given these conflicting properties, both the American Concrete Institute (ACI) and the Portland Cement Association (PCA) guidelines call for fillers to be “semi-rigid.” Semi-rigid fillers are compromise fillers. They are stiff enough to support traffic, but have low-range adhesive and tensile strengths so they will separate adhesively or cohesively when joints open. More specifically, ACI and PCA call for the filler hardness to be a minimum of Shore A80. This is comparable to the hardness of a hard rubber.

Most filler manufacturers have increased their Shore hardness over the years (to A85-95) in response to the use of smaller diameter, harder wheels by the material handling industry.

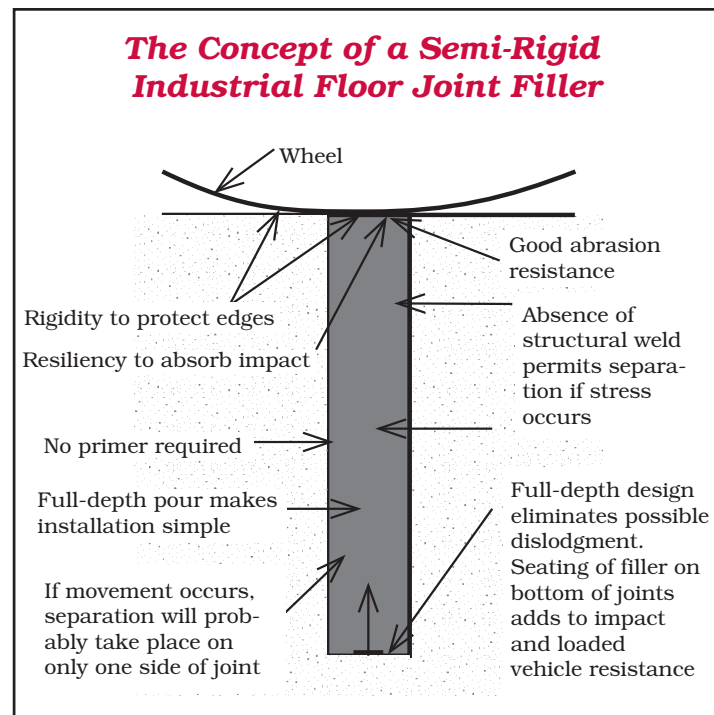

**While there is no truly “ideal” industrial floor joint filler, semi-rigid fillers focus on the joint edge protection needs of a floor through sufficient rigidity to support loads while avoiding slab restraint through lower adhesive and tensile properties.**

## VII. JOINT FILLING (continued)

The two common types of semi-rigid fillers available are epoxies and polyureas. Both are two-component materials, and must be 100% solids (no solvents) to meet ACI and PCA criteria. They must also be pour-grade to achieve the filling depth recommended. Aside from their chemical composition, the biggest difference between epoxies and polyureas is their cure time. Epoxies typically take 4-8 hours to attain an initial set time, while polyureas usually have an initial set in one hour or less. A second difference is their ability to cure in cold temperatures. The cure rate of epoxies is slowed by colder temperatures, while most polyureas are not as temperature-sensitive. Epoxies should be used only in temperatures above 35 degrees F. Many polyureas can be used in sub-zero temperatures. Always verify acceptable installation and service temperature ranges with the joint filler manufacturer.

In general, semi-rigid epoxies and polyureas have comparable adhesive capabilities, lateral (side-to-side) expansion capabilities, and durability in service. High adhesion strength is not a desirable characteristic because it can lead to tearing off concrete edges. As to expansion, do not expect epoxies or polyureas to expand more than 5-15% before separating adhesively or cohesively. Don't be misled by a filler's "elongation" claims. Joints "expand," not elongate. Polyureas tend to be more sensitive to moisture in the joint. In some cases joint dampness can cause polyureas to bubble or foam during their cure. Epoxies generally are not moisture sensitive.

The timing of the filler installation is critical. Since joints are continually widening as the slab shrinks, it is advisable to defer the filling as long as possible. By waiting the joints get continually closer to their eventual final width. ACI and PCA both recommend deferring the filling until the slab is 60-90 days old, longer if possible. It is ideal to wait until the facility is temperature controlled, since both heat and AC help the slab stabilize in dimension.

In the case of coolers and freezers, filling should not take place until the room has reached its ultimate operating temperature, and been stabilized at that temperature. For coolers the recommended period is 48 hours minimum; longer is better. For sub-zero freezers, a 14 day waiting period is advised.

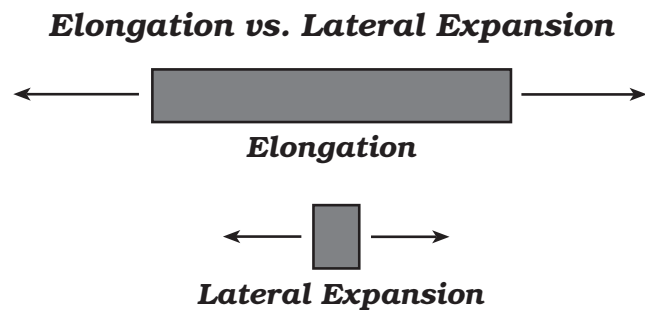

*Often a filler's elongation property is equated with its ability to open with a joint as shrinkage contraction occurs. But joints expand, they don't elongate. Don't be misled into thinking that a filler's elongation property equates to its lateral expansion capability. The two are not the same.*



*The timing of the filler's installation is critical. Filling joints too early after slab placement (or before temperature draw down and stabilization in freezer/cooler rooms) can result in filler adhesion loss and separation from the joint walls, potentially leaving the joint edges exposed to impact and deterioration.*

## VII. JOINT FILLING (continued)

Good joint preparation (cleaning) is vital to a durable filler installation. The filler must bond directly to clean, bare concrete if it is to be effective. The only satisfactory means of cleaning a joint is to re-saw it, ensuring the blade hits both inner walls in a consistent manner. The sawing must remove all dirt, saw laitance and any curing or sealer films deposited. It is advisable to run the blade along one wall, then reverse directions and clean the other wall. Cleaning should always extend to the full depth of the saw cut, or 2" (50 mm) in construction joints if they are not saw cut. The joint cleaning saw should be a dry-cut type, preferably vacuum equipped.

Semi-rigid fillers are typically formulated with low-range adhesive strength to minimize the chances of restraining slab movement during shrinkage. The intention is to have the filler separate adhesively (or internally) as the joint widens.



*Joint preparation (cleaning) is critical in ensuring long term filler durability. The use of dry-cut type, vacuum equipped saws to clean joints is the preferred method of preparation.*



To compensate for low adhesion, fillers must be installed full depth in saw cuts. By filling full depth the bottom of the cut provides support for the filler when loads are imposed. Compressible backer rod should never be used at the base of saw cut joints because it negates the solid support provided by the cut bottom. If it is necessary to “choke off” the bottom of a saw cut to prevent material loss, dry bagged silica sand may be used in accordance with the filler manufacturer's data.

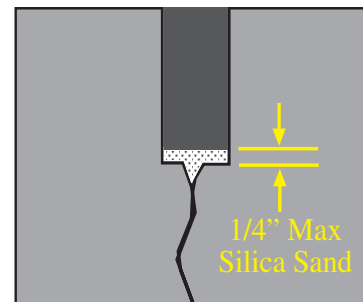

**CONTRACTION JOINT**

Bottom-bearing support is another reason why ACI and PCA recommend that construction joints be saw cut. If construction joints are not sawn, and thus lack a supportive filler base, the filler should be installed at least 2" (50 mm) deep. The additional filler-to-concrete bond helps hold the filler in place as loads are imposed.

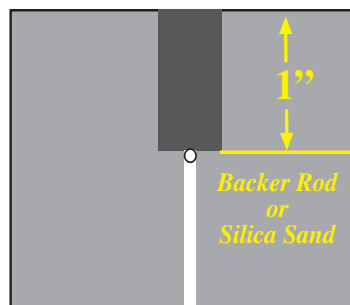

**SAW CUT CONSTRUCTION JOINT**

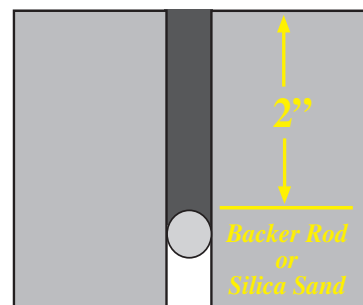

**THRU-SLAB CONSTRUCTION JOINT**



## VII. JOINT FILLING (continued)

The only correct finished profile for a semi-rigid filler is “flush with the floor surface.” A flush filler profile facilitates the smooth flow of hard wheeled traffic across the floor without impact. The only way to achieve a flush profile with a pour-grade filler is to overfill (crown), then razor-off the overfill after the material has cured into a solid.

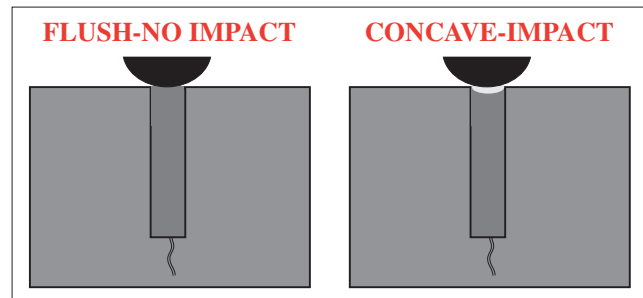

Most epoxy manufacturers recommend using a two-pass method of installation, with perhaps 30-90 minutes between passes. This allows the first pass to reveal any gaps below that could result in a concave profile. Polyureas are often dispensed in one pass, filling from the bottom-up to avoid air entrapment. Consult each manufacturer's data. Epoxies generally razor off flush. Polyureas tend to have a very slight concaveness after razoring. This is due to their rubbery nature, which pulls as the razor cuts through.

If an epoxy cures concave, the recommended correction procedure is to saw cut the filler down 1/2" (13 mm) and refill in a crowned profile. Since polyureas cannot be sawn, the only recourse is to apply a “cap bead” after cleaning and/or roughening the surface. Cap beads may prove less durable due to their tiny mass and limited bond surface.

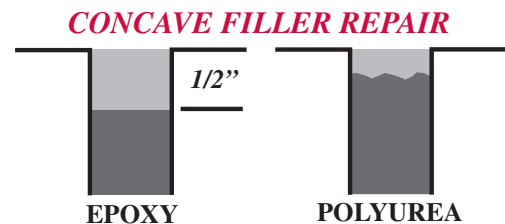

When epoxies and polyureas are overfilled, they generally leave a stain on the surfaces adjacent to the joints. This stain may be objectionable to the facility owner. When staining is not acceptable, the adjacent surfaces should be treated with a film that prevents the filler from contacting the concrete. There are proprietary stain preventing products available from some filler manufacturers, or the surface can be coated with a soap or wax that is water-soluble for removal after razoring.



*The use of a stain preventing film can reduce or eliminate slab surface staining from epoxy/polyurea filler overfill. Other stain prevention methods include applying soap or wax.*



***Polyureas, due to their fast gel times, require the use of dual-component pumps to install. Epoxies can be dispensed manually through bulk caulking guns or through a dual-component pump as well.***

Due to their fairly rapid gel and set times, polyureas must be installed using a dual-component pump machine. Epoxies may be power-dispensed with pumps, or installed using manual “bulk” caulking guns. Maintaining the correct part A to part B ratio is critical with pump systems. Off-ratio materials may not cure.

## VII. JOINT FILLING (continued)

Steel armored joints may be filled with a semi-rigid, or they may be “sealed” with an elastomeric (polyurethane, etc.) sealant, depending on the circumstances. If joints are armored because they are expected to open significantly, as with large pour segments, a sealant may be used initially. The sealant is often removed and replaced with a semi-rigid filler once the sealant fails, when the joint width exceeds 3/8" (10 mm), or once the floor has stabilized in dimension.

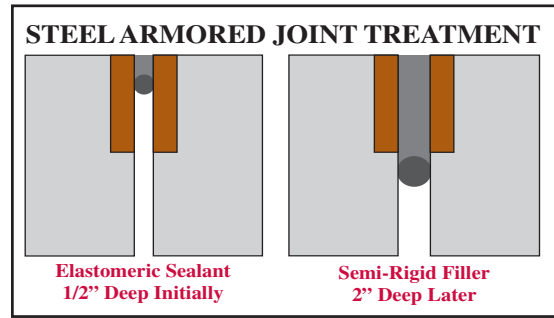

If the joints are armored because of anticipated traffic loads and frequency, a semi-rigid should be used from the start. Joints at the end of long strip pours (post-tensioned slabs, etc.) may exhibit dramatic movement over a long period of time, and multiple filler installations should be expected. Armored joints should always be filled at least 2" (50 mm) deep. Abrasion of the bond faces of the steel is recommended to give the filler both chemical and mechanical adhesion.

It is not unusual for joints to have edge chips prior to the filler installation. These chips may be the result of construction traffic, poor sawing techniques, etc. Minor edge chips may be filled as part of the filling installation. If the chips are more than 1/16" (2 mm) in width, it may be wise to “square them off” prior to filling so the filler flows into them and prevents them from further deterioration.



*Minor edge chipping is not unusual on new floors to be filled. Chips wider than 1/16th" (2mm) should be “squared off” prior to filling.*

In recent years many filler installations have turned colors, often changing from gray to a yellowish tone. This color change has been traced to the UV rays emitted by various lighting systems. While aesthetically objectionable, there is no indication that the fillers are adversely affected. Removal of the discolored surface will prove futile since the newly exposed filler will also discolor.

When filling joints under an impervious covering like tile or hi-build coatings, one should be concerned about potential “filler extrusion.” Covered floors typically have a vapor retarder beneath the slab. This prevents the substantial moisture at the bottom of the slab from dissipating. When the floor covering is applied, the moisture within the slab is encapsulated.

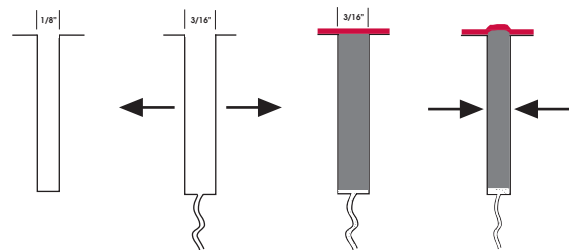

*Filler installed under an impervious covering may extrude or “hump” if slabs expand due to encapsulated moisture.*

As the moisture in the slab equalizes, it is possible for the rising moisture to cause a re-expansion of the upper slab. This re-expansion can “extrude” the filler, causing a “hump” under the tile or coating. This phenomena does not happen on a consistent basis, and it can happen anywhere regardless of geography or climate. The best means of preventing filler extrusion is to fill earlier than normal, allowing for separation to occur before the covering is applied.

## **VII. JOINT FILLING (continued)**

The cost of a “properly” performed semi-rigid filler installation for an ambient temperature project will range from about \$1.25 to \$2.00 per lineal foot (labor + material). This cost will vary depending on joint depth and width, size of the project, work area access, presence of edge chipping, local labor rates, etc. Filling in cooler rooms will run a bit higher, and filling in freezer rooms can be double that for ambient areas due to reduced productivity. While these costs may appear expensive, bear in mind that the overall long-term durability of the floor often depends upon the quality of the joint protection provided. Also bear in mind that the repair of improperly filled joints can cost \$3 to \$10 per lineal foot, not including the costs to the owner's operational productivity.

Based on findings by our staff, and many floor experts, as many as 80-90% of all joint filler installations are likely deficient. These deficiencies can be attributed to a number of reasons, the most common being intentional cheating, sloppy workmanship, or the failure to understand the difference between “filling” and “sealing.”

The best way to avoid having deficiencies is to prevent them. Specifications should be tightly drafted and comprehensive. Bid prices substantially lower than those referenced above should be questioned and realistic numbers should be carried into the project for the joint filling contract. Pre-slab meetings should be held discussing the joint filler installation specifications and expectations. Having a sample installation performed before the start of actual work is also strongly recommended. Full depth material filling can be verified by drilling through the cured filler. If the drill bit “plunges,” the depth is suspect.

***An estimated 80-90% of joint filler installations are performed improperly...***



***Full joint depth of the filler is easily verified by drilling through the cured filler.***



## VIII. POST-FILLING

If there is one “given” with concrete floors, it is that almost every joint will exhibit filler separation. This is obviously due to the continued shrinkage of concrete after the joints were filled. The separation may be adhesive or cohesive. Polyureas generally will separate adhesively, and continually along one side of the joint. Epoxies generally separate in a “leap-frog” manner, with the adhesive separations jumping from side to side. Cohesive separation is not unknown for either product, but it is less common than adhesive. While filler separation may not be aesthetically pleasing, it does not in itself render the installation unacceptable or deficient.

Acceptability of a separated filler is generally determined by whether it continues to protect the joint edges, and whether the smooth flow of vehicle traffic is affected. There are no specific industry standards.

### Filler Separation

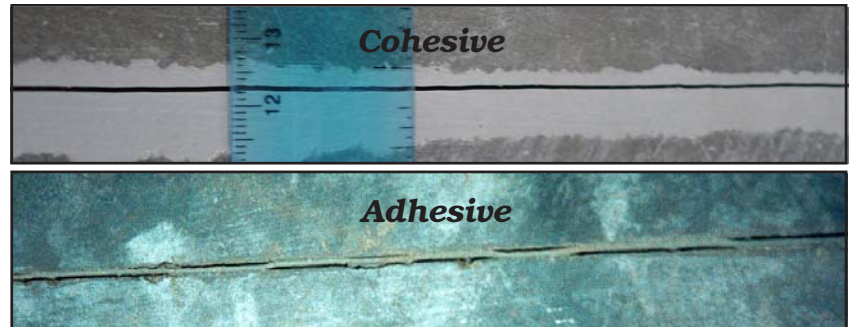

As a rule of thumb, most fillers will protect joint edges if the separation voids do not exceed credit card width, and if they remain held firmly in place. Once separation reaches credit card width, the condition should be regularly monitored. If the voids exceed credit card width, corrective measures should be considered in order to prevent edge spalling. If the filler becomes “loose,” or if edge spalling starts to develop, corrective measures should be undertaken without further delay.

Corrective measures for separation are different for semi-rigid epoxies and polyureas. With epoxies you can refill the separation voids with a thin viscosity filler provided by some manufacturers, or saw out the top 1/2" (13 mm) of the original filler and refill using the same filler. With polyureas you are limited to filling in the separation voids because they generally cannot be sawn. When sawn, they either revert back to an uncured oily substance, or shred like cotton candy and bind up the saw. These corrective limitations should be considered when specifying the original filler. If either type of filler is loose, it should be totally removed and replaced after the joints are properly cleaned.

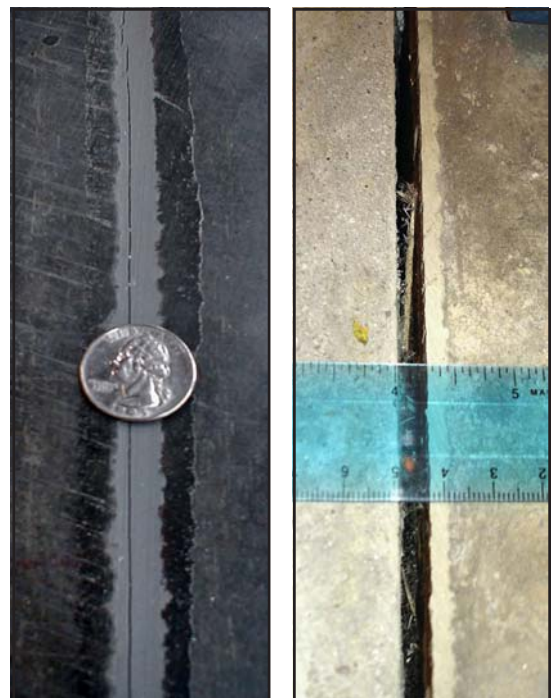

*The need for correcting separation depends upon the degree of separation and the vulnerability of the joint edges. Separation shown on left is minor and may not warrant correction. Separation on right should be corrected.*

## VIII. POST-FILLING (continued)

Responsibility for correction of filler separation is frequently a source of conflict on projects. The applicator's defense is that he filled the joint that existed, and should not be held responsible for shrinkage of the concrete. The owner's position is that he paid to have the joints filled and protected, and wants them traffic-ready and durable. Both arguments are valid. Project specifications should be clear on responsibility for separation correction, and the repair of any edge spalling that occurs due to separation. It should not be part of a contractor's normal one year warranty because separation itself does not constitute workmanship deficiency.

Some specifications ask that the bidder include in his price a call-back after 6 months to correct separations. Other specs ask for a unit price "add" for correction. Still others make correction the responsibility of the facility owner. All these options offer negative and positive aspects since nobody can predict the extent or severity of correction.

### Filler Separation Correction Methods

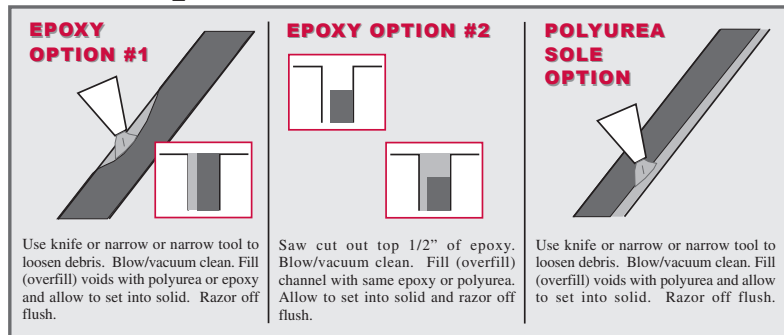

The same conflict can arise when joint fillers become distressed or loose due to "rocking slab" conditions. Rocking slabs are caused by curl. If slab panels deflect under load, the filler will be sheared off at its bond points. Rocking slabs can also result in severe joint edge deterioration as hard wheels hit the adjacent panel edge. Correction of the filler at curled joints, and/or spalls, is wasted money unless the offending panels are "stabilized."

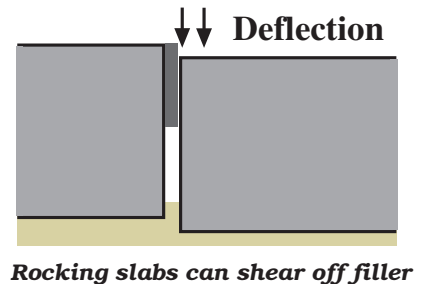

The most common means of stabilizing slabs is to fill the voids beneath the panels with a grout or other supportive materials. Certain polyurea fillers are now being used for this process due to their rapid set time, often allowing for the return of full traffic within hours.

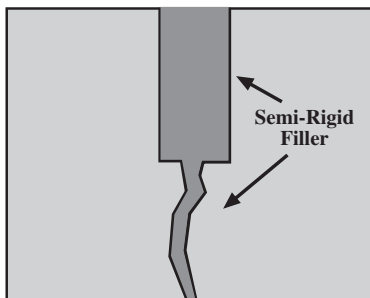
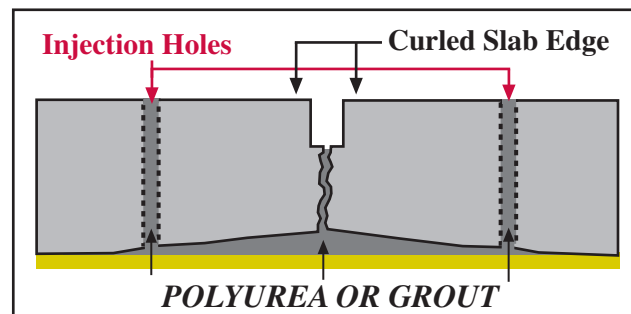

**Gravity-flowing thin semi-rigid into joint can sometimes restore load-transfer.**

If the rocking is minimal, correction can sometimes be achieved by gravity-flowing a thin semi-rigid into the joint. If the penetration is substantial, the cured semi-rigid filler can create enough friction against the joint walls to reduce or eliminate vertical deflection. Gravity-filling works best in sawn contraction joints where it can fill the voids between the irregular surfaces of the crack.

## VIII. POST-FILLING (continued)

In some cases filler distress and edge spalling may appear to be the result of normal slab shrinkage, when in fact the actual cause is improper filler installation. One sign of poor installation is when the top of the filler has dropped below the floor surface. This usually turns out to be a case of the filler not being full depth. If the filler has broken bond from both walls, even though the separations are very thin, it could indicate that the joint was not properly cleaned and the filler was not adhered to the concrete.

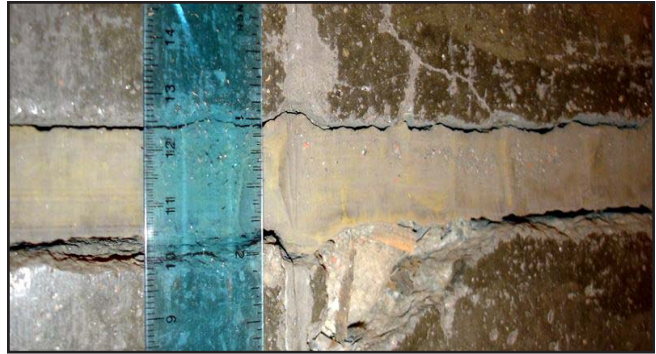

*If joint filler has dropped below the floor surface or was not flush originally, joint edge spalling may occur.*

It is the author's opinion that the repair of spalled joints should be initiated before they begin to adversely affect facility operations (cause wheel or vehicle damage, etc.). But it is also wise to defer the repairs until the slab shrinkage rate has significantly slowed, and the joint dimension appears stable. The ideal time to perform repairs is in the winter months when joints will likely be at their widest point due to thermal considerations.

The repair procedure for spalled joint edges is dictated by the underlying cause of the damage, and the width of the spall. The edges of saw cut joints can sometimes deteriorate because of micro-fracturing resulting from a faulty sawing operation. Edges of construction joints may be spalling because they lacked adequate densification during troweling, were inherently weak due to inadequate curing, or the top surface of the slab is showing signs of delamination.

For spalls with an overall width of up to 1/2" (13 mm), make a 1/2" to 1" (25 mm) deep saw cut just beyond the outer point of spalling, remove the concrete and filler between the cuts, and refill with a semi-rigid filler. For spalls 1/2" to 1" wide follow the recommendations of the filler manufacturer. Some epoxy manufacturers will recommend field-modifying their semi-rigids with silica sand to increase its cured hardness. For spalls wider than 1" (25 mm) it is usually recommended that the edge be rebuilt with a "structural" epoxy grout. A saw cut can be made through the cured structural epoxy to recreate the joint, which is then filled with a semi-rigid. In some cases the best repair filler may be a polyurea, whose fast-set properties will allow an earlier return of vehicle traffic. Their negative is that they cannot be ground or sanded. Other times an epoxy may be the best choice, since they offer longer working times, a more flush repair, and can be ground level.

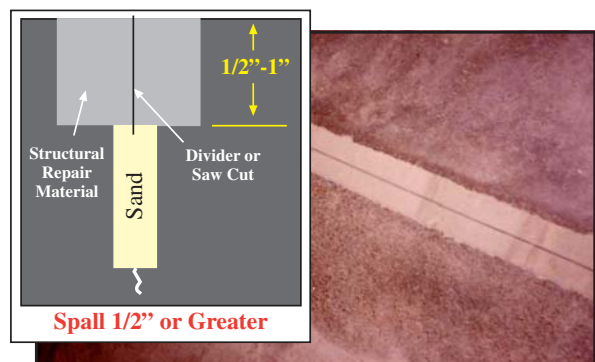
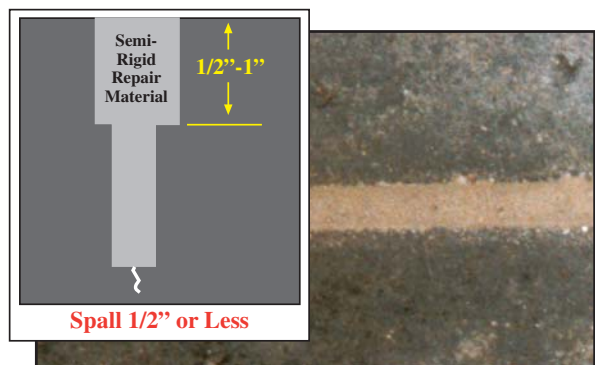



## **IX. THE FIRST YEAR**

During the owner's first year of occupancy his focus is rightfully on his operations. He may not pay attention to joint deterioration that is related to ongoing concrete shrinkage. Even if he is aware of damage, he may not bring it to anyone's attention, assuming that the contractor's warranty will cover all defects noted at the one year walk-through. This is a prescription for trouble and potential conflict, even legal actions.

By allowing a full year of deterioration to occur, minor edge chipping can evolve into major repair costs. It is strongly recommended that the owner and the GC arrange for interim floor inspections to keep minor problems minor. Unless the project specifications clearly identify who should bear the cost of post-occupancy corrections, the owner and GC may wish to negotiate the cost responsibility between themselves. The bottom line is that joints should never be allowed to deteriorate because joints are a key to long-term floor durability.



## **X. SUMMARY**

The phrase "the devil is in the details" may well have first been coined by a concrete contractor. Despite our best design and construction intentions and practices, slab placement is still a highly complex system that can be undermined by human error, timing problems, small details, even the weather. When all components are not in perfect sync, the resulting problems often manifest themselves at the joints. Joints are also a "system" within the overall slab system. The highest quality floor finish will soon be forgotten if the joints deteriorate under the owner's material handling vehicle wheels. It is the author's observation that of all the legal conflicts regarding floors, more than 50% are related to joint deterioration, often involving curl.

We must always remember that joints are an integral and vital part of the floor surface, perhaps even the most vulnerable part of a slab. We forget this at our own risk.